

oto

Connect. Set. Forget.

Your journey to effortless lawn care starts here.

Contents

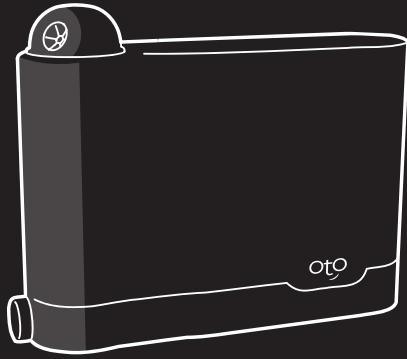

OtO device

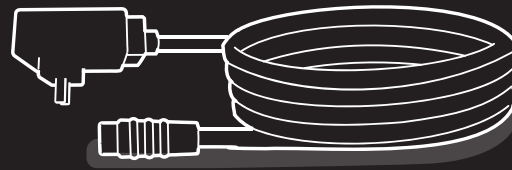

50 ft. power cable x 1

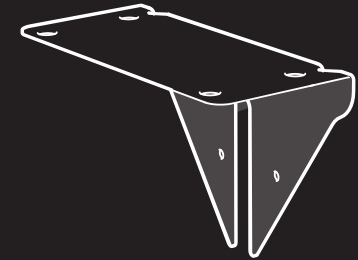

Mounting bracket x 1

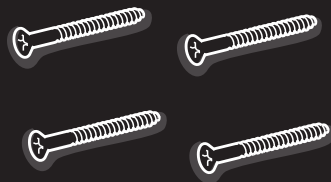

Wood screws x 4

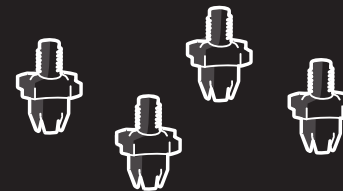

Thumb screws x 4

1. Before installing OtO

Wi-Fi signal

OtO uses 2.4 GHz and requires constant access to a strong Wi-Fi signal. Test the Wi-Fi strength with the app before you place your device. Your phone's Wi-Fi signal will be higher than what OtO will receive.



TIP: If you are using an iPhone, make sure it is connected to the same Wi-Fi network as OtO.

Sunlight & power tips

The on-board solar panel requires at least 3 hours per day of direct, unobstructed sunlight.

If your device's location does not receive enough sunlight, use the provided power cable and wall adapter as a permanent power source or as a boost when needed.



WARNING:

- Before connecting the power adapter to OtO, make sure both connectors are completely dry. Moisture caught between connectors during charging can cause pin corrosion and breakage.
- Keep the power connector capped when not in use. Leaving the pins exposed to water may cause irreversible power damage.

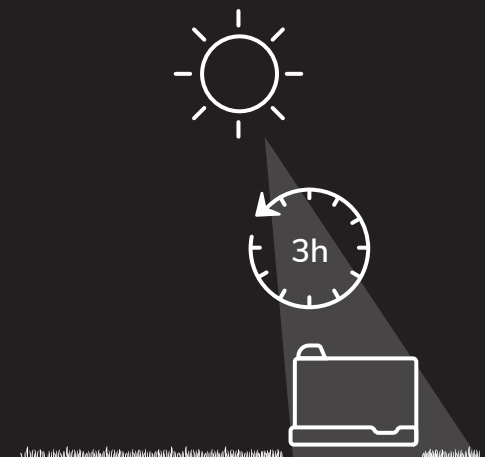
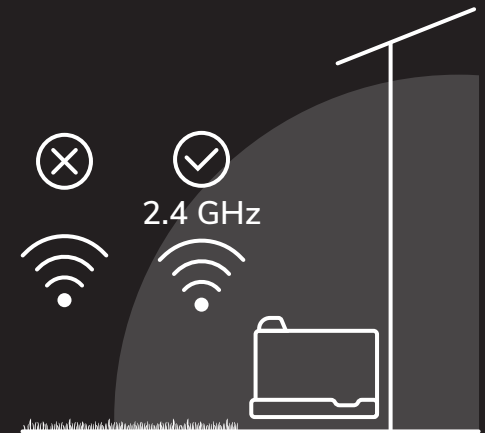

1. Before installing OtO (continued)

Hose requirements

Ensure you have a compatible hose:

- Only use high-quality rubber hose
- 5/8" or 3/4" INNER diameter
- Do not use flex/expandable/light-duty hoses

Water pressure requirements

Ensure a full spray distance (40 feet) by minimizing pressure loss:

- Pressure at end of hose must be 50 PSI or greater
- Use as short of a hose as possible (max 50 feet)
- Avoid using hose connectors or splitters



WARNING:

- Use only brass or plastic couplings. Do not connect OtO to aluminum or steel hose ends (will cause corrosion).
- A pressurized hose may burst in high heat. Do not leave your hose pressurized and exposed to the sun.
- Do not use any tools to secure the hose connection.



How to estimate OtO's reach

To estimate distance, walk outwards from OtO. 40 feet is approximately 16 walking steps. (average stride = 2.5 feet)

2. Add new device

1. Download the free OtO Lawn app



2. Launch the app and select: Add a new OtO

3. Follow the app's instructions to complete Wi-Fi setup



TIPS:

- OtO only works with 2.4 GHz. If you have a dual-band router, make sure to connect to a separate 2.4 GHz band - not the 5 GHz band.
- We recommend reaching out to your router or internet service provider (ISP) for guidance.
- If you are having trouble connecting, double-check that your Wi-Fi password is correct.

We're always here to support.

Visit our Help Desk for articles, photos, and videos.



support.otolawn.com

In-App

Select "Report issue" in the app's main menu

Email

care@otolawn.com

Phone

1-833-473-3617

3. Installation



WARNING: Always secure OtO with the provided mounting bracket to prevent it from tipping over or causing inaccuracies in the designated zones. Please note that any damage caused by dropping the device is NOT COVERED BY WARRANTY.

Ground installation

1. Push the mounting bracket into the ground until the top is flush with surface. Use a blunt piece of wood as a mallet, if necessary
2. Attach the four thumb screws to the device
3. Push the device's 'feet' into the bracket holes until all four are clicked into place

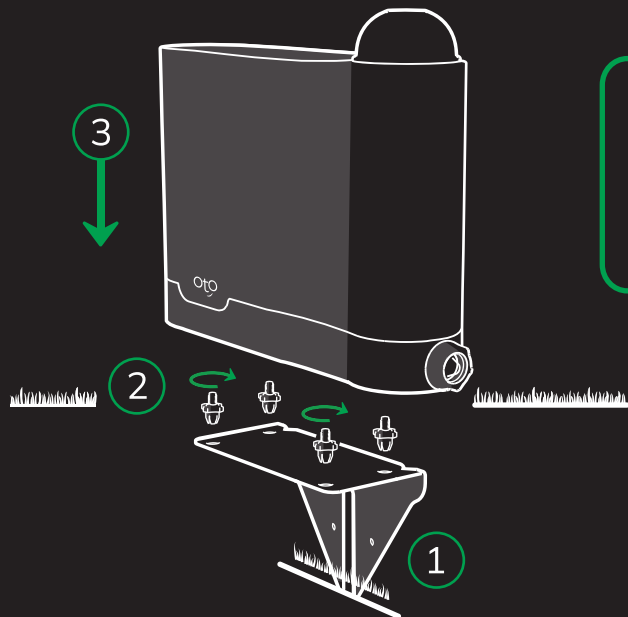

TIP: To remove from bracket: Pinch one thumb screw, and firmly pull at an angle.

Fence/wall installation

1. Use the four included screws to secure the bracket into a wood fence
2. Pass the threads on the 4 thumb screws through the mounting bracket holes
3. Secure the thumb screws to the device

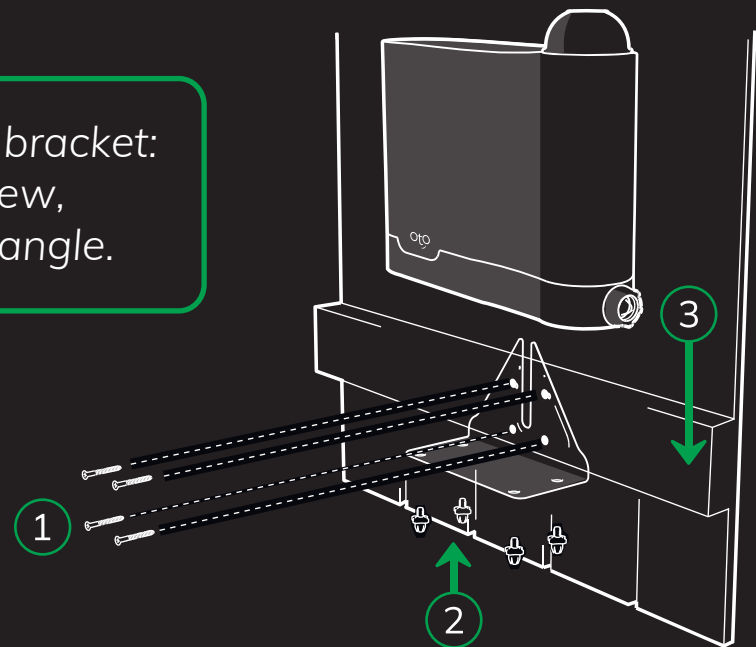

4. Create zones

1. Use the OtO App to define zones and customize watering schedules. Create any combinations of these three types of zones:

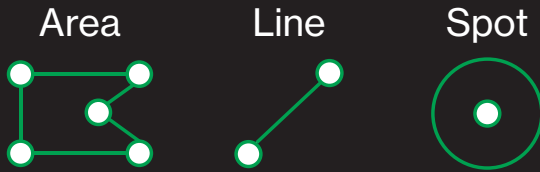

2. Use the app's "Water now" function to test your zones

Troubleshooting water reach

If the device does not reach 40 feet, check the following:



- ✓ Water source must be fully open



- ✓ Ensure there are no kinks, bends, coils or leaks in the hose (see Hose Requirements in Step 1)



- ✓ Remove any connectors or splitters along the line



TIP: Learn how to improve your home's water pressure and other tips:



5. Maintenance

- Keep OtO clean using a damp cloth. Do not use abrasive chemicals. Keep the solar panel clean and unobstructed
- Periodically throughout the season check the hose gasket filter is clean

❄️ How to put OtO away for the winter.

1. Protect OtO's battery life by turning on Winter Mode in the app
2. Turn off water source and then drain the device completely of water
3. Store indoors where it will not freeze
4. Keep plugged in OR charge covered in the spring



WARNING: Do not leave or operate the device in freezing temperatures

☀️ How to reinstall OtO in the spring.

1. Charge OtO for 3 hours with solar panel covered
2. Take OtO out of Winter Mode using the app
3. Re-install or double check your hoses and hose routing
4. Ensure there is no debris in any of the hose connections
5. Test your zones using the "Water now" function in the app

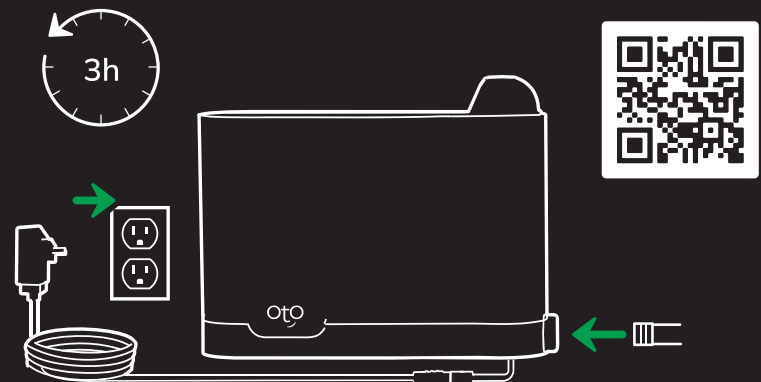
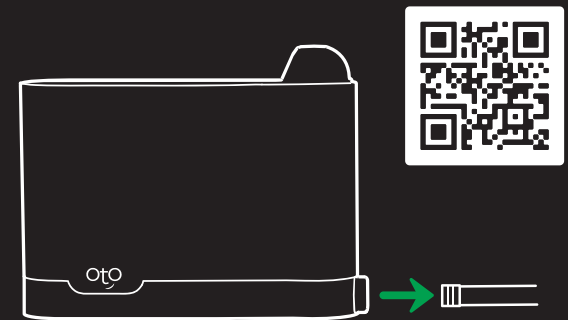
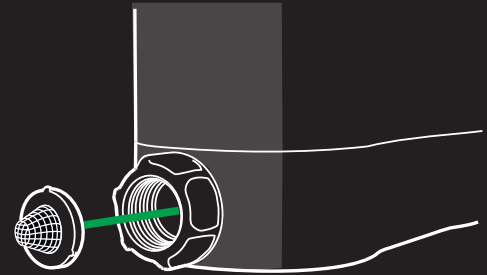

Warranty & legal

For Warranty information, visit <https://otolawn.com/pages/warranty>

For battery recycling, visit call2recycle.org or call **1-800-822-8837**



WARNING: To prevent contamination of your drinking water, ensure that the faucet connected to OtO is equipped with a backflow device. Government regulations determine the specific type and maintenance requirements of the backflow device needed when connecting a device like OtO to the water supply. Regulations may vary by municipality, so it's essential to install and maintain the appropriate backflow device for your area. OtO is not liable for any damage or harm resulting from failure to comply with these requirements.

NOTE: This equipment has been tested and found to comply with the limits for a Class B digital device, pursuant to part 15 of the FCC Rules. These limits are designed to provide reasonable protection against harmful interference in a residential installation. This equipment generates, uses and can radiate radio frequency energy and, if not installed and used in accordance with the instructions, may cause harmful interference to radio communications. However, there is no guarantee that interference will not occur in a particular installation. If this equipment does cause harmful interference to radio or television reception, which can be determined by turning the equipment off and on, the user is encouraged to try to correct the interference by one or more of the following measures: —Reorient or relocate the receiving antenna. —Increase the separation between the equipment and receiver. —Connect the equipment into an outlet on a circuit different from that to which the receiver is connected. —Consult the dealer or an experienced radio/TV technician for help

© 2025 OtO Lawn.

All rights reserved. OtO and the OtO design are trademarks of OtO Inc.

Information subject to change without notice. [0294-E]